

Series BW and BWU

Euroline unit



BW900 • BWU900 ▶

- Basic converting line for garbage bag production including a non driven C-folder
- In- or Offline configuration – with or without surface unwind
- Flexible unit, easy to operate and maintain
- Servo driven
- A combination of well proven FAS sealing, perforation and winding unit forming one complete line setup
- Sealing from two sides with single sealing bars
- Unique tensionless sealing system
- Optional equipped with – PP-insert and TU220 tape unit





BW900



BWU900

BW900, BWU900

This unit is optimized for garbage bag production, in- or off-line. Equipped with a non driven C-folder and single sealing bars as standard. With FAS tensionless sealing operation and heating from two sides, it enables LLD, LD, MD, HD, recycled and biomaterial to be converted into a garbage bag on roll. The TU220 tape unit is the only optional equipment which can be attached.

Technical data	BW900	BWU900
Master roll max diameter, mm [in]	800 [31.5]	
Web width sealing max, mm [in]	860 [33.9]	860 [33.9]
Bag length, min-max, mm [in]	600-3000 [23.6-118]	600-3000 [23.6-118]
Machine speed, m/min [fpm]*	20-100 [65.6-328]	20-100 [65.6-328]
C-folding, mm [in]	220-620 [8.7-24.4]	220-620 [8.7-24.4]
Cycles/min, max	160	160
Web width winding, mm [in]	100-500 [3.9-19.7]	100-500 [3.9-19.7]
Roll changes/ min, max**	8	8
Max roll diameter, mm [in]	200 [7.9]	200 [7.9]
Installed power, kW [A]	5 [9]	5 [9]
Air supply, bar [psi]***		
L x W x H, mm	2800 x 1950 x 2022	4050 x 1950 x 2022
L x W x H, [in]	[110 x 77 x 80]	[159 x 77 x 80]
Weight, kg [lbz]	2300 [4409]	2600 [6173]

** With tape unit TU220 max 6/min.
*** 6,13 lt/roll change [87 at 4.6 scfm]

Standard



Single bar



C-Folder

Optional



Tape - TU220

BW900

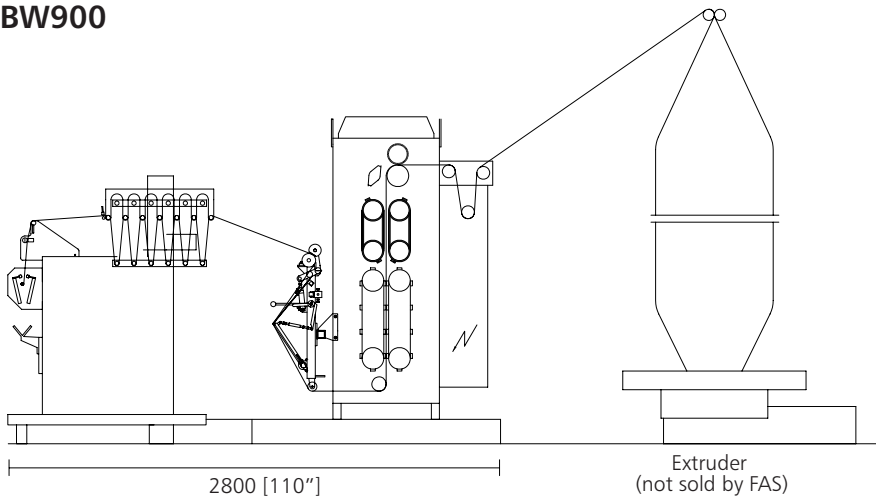

BWU900

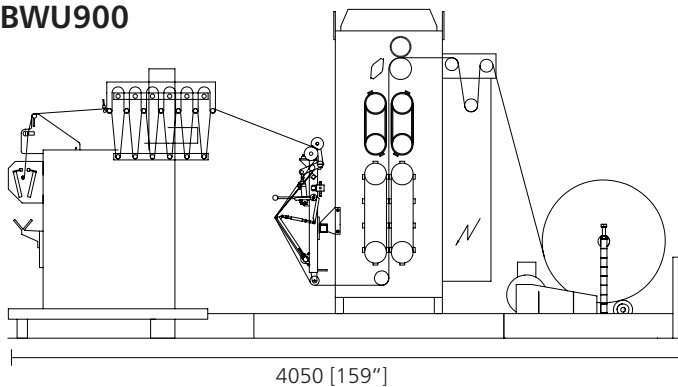

* **Mechanical** Max production speed depending on the quality (i.e. thickness, number of layers etc) of material to be converted.
Mainpower All units mainpower 380-420V +10%/-15%, for temporary power surge, 16A, 3phases, 50Hz, ground and neutral.
 All technical data are subject to change without prior notice.



FAS Converting Machinery AB
 Ynglingavägen 62.
 SE-245 65 Hjärup.
 Phone: +46 (0)411 692 60.
 Fax: +46 (0)411 127 40.
 sales@fasconverting.com
 www.fasconverting.com



PECO Inc.
 2 Stewart Place.
 P.O. Box 1346, NJ 07004, USA.
 Phone: +1 973 882 0512.
 Fax: +1 973 882 0915.
 info@pecofas.com
 www.fasconverting.com

Agent