



Series O

# Optional units



SF2V • SFC • TU220 • WD750 ▶

- TU220 – Tape unit
  - Short overlap saves paper and money in every cycle
  - Standard equipped with photoeye
  - Easy to operate and maintain
- SF2V – single or double V-folder, free standing with a driven nipp
- SFC – Free standing fixed C-folder with a driven nipp
- WD750 – Web diverter for two lanes with a driven nipp

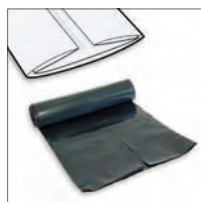
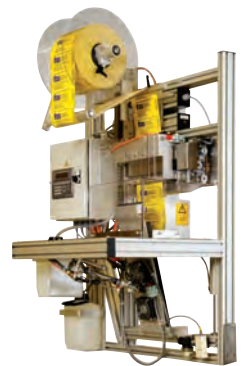



SFC



SF2V



TU220

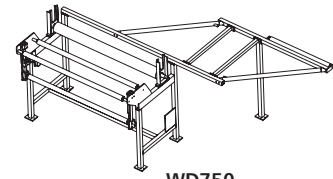

WD750

## SFC

The SFC folding unit is used for single lane production folding a C on a fixed plate size. The unit is freestanding. The driven nip and dancer enable the unit to be used independently and follow any machine setup or together with a FAS machine line.

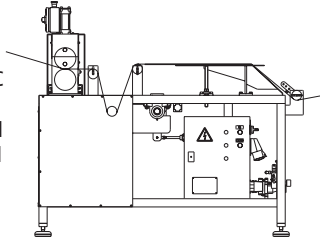

Technical data	SFC
Web width infeed, max mm [in]	500 [19.7]
Machine speed, m/min [fpm]*	10-200 [33-655]
Installed power, kW [A]	2,2 [3.5]
Air supply, bar [psi]	6 [87]
L x W x H, mm	1650 x 1050 x 1450
L x W x H, [in]	[65 x 42 x 58]
Weight, kg [lbs]	270 [596]

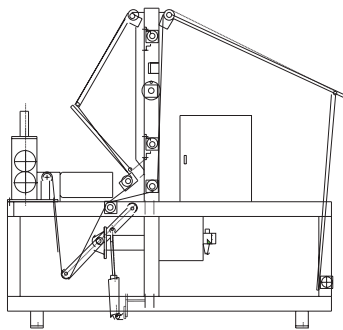

## SF2V

The SF2V folding unit can fold single or double V-fold in the web direction. The unit is used for single lane production and it's freestanding. The driven nip and dancer enable the unit to be used independently and follow any machine setup or together with a FAS machine line.



Technical data	SF2V
Web width in max-min, mm [in]	1100 [43.3], folding to 1/4
Web width out, max-min, mm [in]	285 [11.2]
Folding	Single or double V
Machine speed, m/min, [fpm]*	120 [393.7]
Machine speed, m/min, [fpm]*	200 [656]**
Installed power, kW [A]	0,75 [1.5]
Air supply, bar [psi]	6 [87]
L x W x H, mm	1770 x 1420 x 2000
L x W x H, [in]	[70 x 56 x 79]
Weight, kg [lbs]	510 [1124]

\*\* Optional high speed version.

## TU220

The taping unit covers the range from 50-220 mm tape width. FAS recommend to use a gummed paper quality of 80-90 g/m2 with vegetable glue of 15 g/m2. The unit can work with both length control or with a photocell for print in register. The unit can be mounted to our models SP500/800, TW475 and BW/BWU900. Retrofit to older winder units is possible with some program changes. Contact FAS service for further information.

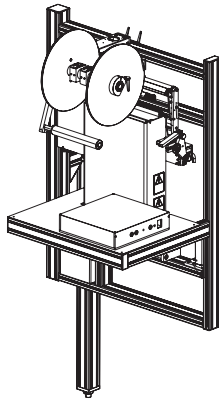

Technical data	TU220
Tape width, mm [in]	50-220 [1.6-8.7]
Tape length, mm [in]	160-420, +/-2 [6.3-16.5, +/-0.125]
Finished roll diameter, mm [in]	40-120 [1.6-4.7]
Master tape roll diam, max mm [in]	250 [9.8]
Master tape roll weight, max kg [lbs]	13 [28.7]
Roll changes/min, max**	12
Main power***	1 phase
Installed power, W [A]	200 [0.85]
Air supply, bar [psi]	6,150 l/min [87 at 5.3 scfm]
L x W x H, mm	700 x 1250 x 1350
L x W x H, [in]	[28 x 49 x 53]
Weight, kg [lbs]	65 [143]

\*\* Dep. on the type of machine to be mounted on.  
\*\*\* 240 VAC, 0,85 A, 1 phase, 50/60 Hz

## WD750

The WD750 unit is a freestanding unit for twin lane bag production. The WD750 has a dancing roller for controlling the nip and speed off the web. The max working width of the WD750 is two lanes with max web width 750mm when entering the unit.

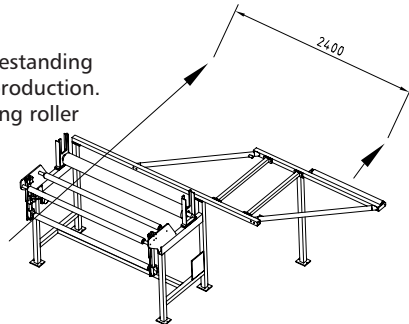

Technical data	WD 750
Web width in, mm [in]	2 x 750 [2 x 29.5]
Outcoming web cc, mm [in]	2400 [94.5]
Machine speed, m/min [fpm]	120 [393.7]
Installed power, kW [A]	0,75 [1.5]
Air supply, bar [psi]	6 [87]
L x W x H, mm	1750 x 3355 x 1230
L x W x H, [in]	[69 x 132 x 49]
Weight, kg [lbs]	500 [1102]

\* **Mechanical** Max production speed depending on the quality (i.e. thickness, number of layers etc) of material to be converted.  
**Mainpower** All units mainpower 380-420V +10%/-15%, for temporary power surge, 16A, 3phases, 50Hz, ground and neutral.  
 All technical data are subject to change without notice.

**fas** converting machinery ab

FAS Converting Machinery AB  
 Ynglingavägen 62.  
 SE-245 65 Hjärup.  
 Phone: +46 (0)411 692 60.  
 Fax: +46 (0)411 127 40.  
 sales@fasconverting.com  
 www.fasconverting.com

**peco** inc.  
 a plastic equipment company

PECO Inc.  
 2 Stewart Place.  
 P.O. Box 1346, NJ 07004, USA.  
 Phone: +1 973 882 0512.  
 Fax: +1 973 882 0915.  
 info@pecofas.com  
 www.fasconverting.com

Agent