



BW900 • BWU900

Series BW and BWU Euroline unit

The Euroline concept is based on the unique technology of FAS system for sealing and perforation, combined with FAS well known winding system.

The Euroline consists of two or three units, linked together, forming one single system for perforation, sealing and winding. The process is easily operated from one operator panel. The unit is servo driven and has two configurations: in-line or off-line.

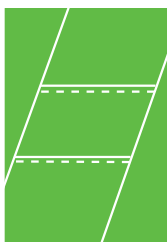



BW900



BWU900

BW900, BWU900

This unit is optimized for garbage bag production. Equipped with a C-folder and single sealing bars as standard, it will handle the main part of your production - from flat film to gusseted and C-folded garbage bags, in HD/MD/LD or recycled materials. To keep it simple we only offer the TU220 tape unit as optional equipment.

Technical data	BW900	BWU900
Master roll max diameter, mm [in.]		800 [31.5]
Web width sealing max, mm [in.]	860 [33.9]	860 [33.9]
Bag length, min-max, mm [in.]	600-3000 [23.6-118]	600-3000 [23.6-118]
Machine speed, m/min [fpm]	20-100 [65.6-328*]	20-100 [65.6-328*]
C-folding, mm [in.]	220-620 [8.7-24.4]	220-620 [8.7-24.4]
Cycles/min, max	160	160
Web width winding, mm [in.]	100-500 [3.9-19.7]	100-500 [3.9-19.7]
Roll changes/min, max	8**	8**
Max roll diameter, mm [in.]	200 [7.9]	200 [7.9]
Installed power, kW [Amps]	5 [16]	5 [16]
Air supply, bar [psi]	6, 13 lt/roll change [87 at 3.7 scfm]	6, 13 lt/roll change [87 at 3.7 scfm]
L x W x H, mm [in.]	2800x1950x2022 [110x77x80]	4050x1950x2022 [159x77x80]
Weight, kg [lbs]	2300 [4409]	2600 [6173]

*Mechanical. Max production speed depending on material to be produced.
 ** With tape unit TU220 max 6/min.

Standard

Single bar

C-Folder

Optional

Tape - TU220

BW900

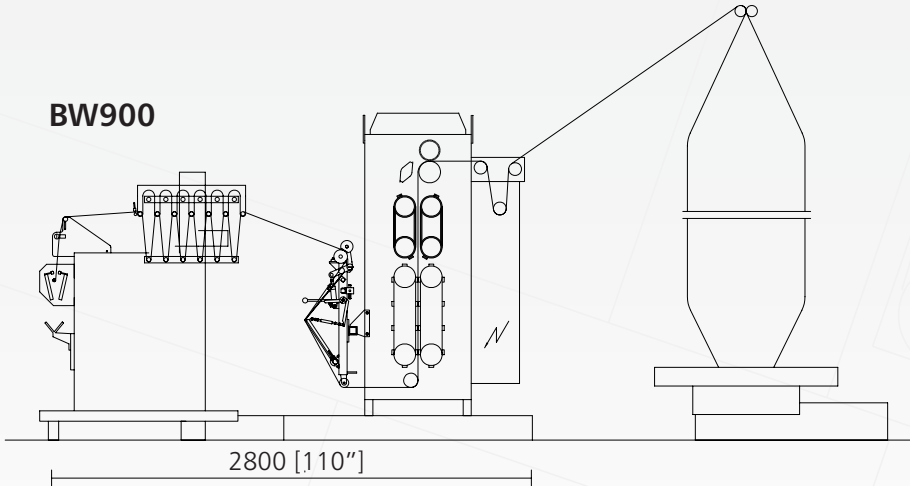

BWU900

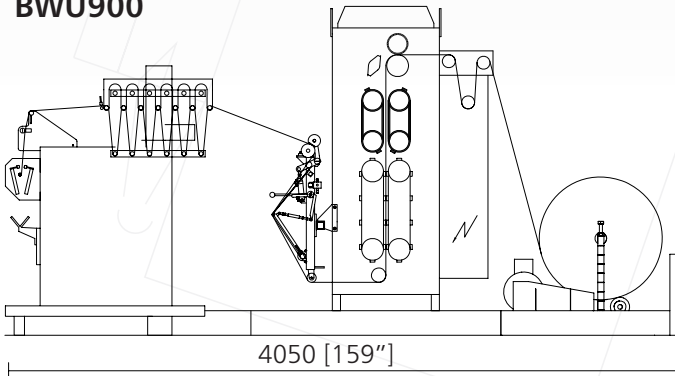

(1). All units main power 380-420V, +10%/ -15% for temporary power surge, 16A, 3 phases, 50Hz, ground and neutral. Subject to alterations. All technical data are subject to change without notice. Production capacity of units depending on material. [...] = Imperial measurements.



FAS Converting Machinery AB
 Box 1503, SE-271 00 Ystad, Sweden.
 Visit: Östra Zinkgatan 1, 271 39 Ystad
 Phone: +46 (0)411 692 60.
 Fax: +46 (0)411 127 40.
 sales@fasconverting.com
 www.fasconverting.com



PECO Inc.
 2 Stewart Place,
 P.O. Box 1346, NJ 07004, USA.
 Phone: +1 973 882 0512.
 Fax: +1 973 882 0915
 info@pecofas.com
 www.fasconverting.com

Agent